

Description

- The CP2102 is a highly-integrated USB-to-UART bridge controller providing a simple solution for updating RS-232 designs to USB using a minimum of components and PCB space. Offering Baud rates aliasing and supporting additional data formats, the CP2102 is a pin-to-pin upgrade from CP2101. The CP2102 also includes a USB 2.0 full-speed function controller, USB transceiver, oscillator, EEPROM and asynchronous serial data bus (UART) with full modem control signals in a compact 5 x 5 mm MLP-28. No other external USB components are required.

Example Applications

- Upgrade of RS-232 legacy devices to USB
- Cellular phone USB interface cable
- PDA USB interface cable
- USB to RS-232 serial adapter

Virtual Com Port Drivers

- Works with existing COM port applications
- Royalty-free distribution license
- Windows 98SE/2000/XP
- MAC OS-9
- MAC OS-X
- Linux 2.40 and greater

Features

USB Function Controller and Transceiver

- USB specification 2.0 compliant; full-speed (12 Mbps)
- Integrated 1024-byte EEPROM for custom Baud rates, vendor ID, etc.
- EEPROM security lock function
- User programmable custom Baud rates
- Integrated transceiver; no external resistors required
- Integrated clock; no external crystal required
- USB suspend states supported via SUSPEND pins

Asynchronous Serial Data Bus (UART)

- All handshaking and modem interface signals
- Data formats supported: 8, 7, 6, 5-bit; 1, 1.5, 2 Stop bits
- Parity: Odd, Even, Mark, Space, No Parity
- Baud rates: 300 bps to 1 Mbps
- 576-byte receive buffer; 640-byte transmit buffer
- Hardware and X-On/X-Off handshaking
- Event character support

Power-On Reset Circuit

Supply Voltage

- Self-powered: 3.0–3.6 V
- USB bus powered: 4.0–5.25 V

28-Pin MLP

Temperature Range: –40 to +85 °C

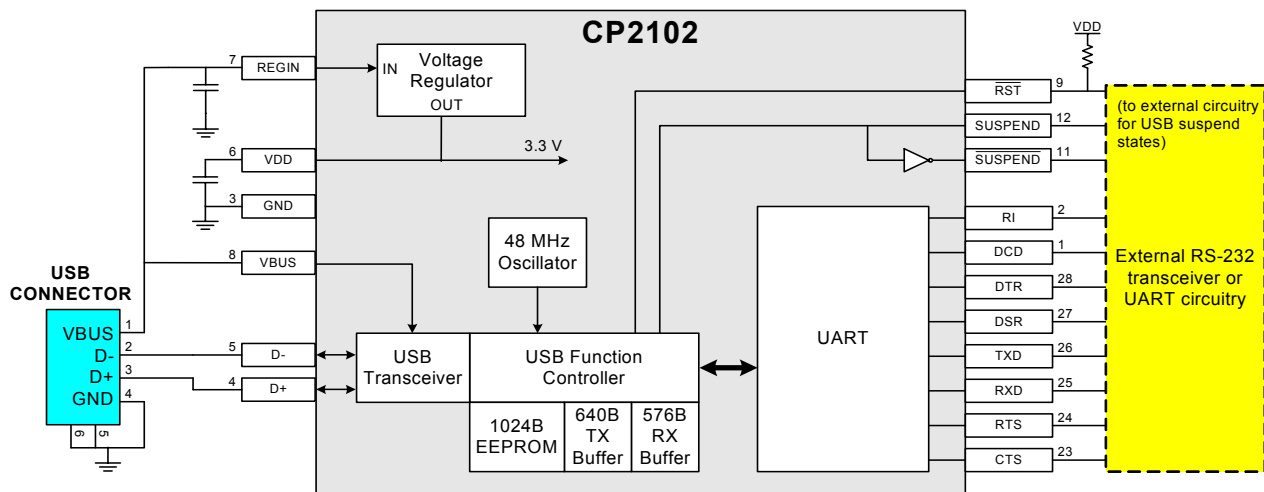

Selected Electrical Specifications

(T_A = -40 to +85 C°, V_{REGIN} = 5.0 V unless otherwise specified unless otherwise specified)

PARAMETER	CONDITIONS	MIN	TYP	MAX	UNITS
Regulator Input Voltage (REGIN)		4.0		5.25	V
V _{DD} (Regulator Output)		3.0	3.3	3.6	V
I _{DD} (Regulator Output)			80		mA
Regulator Bias Current			70		μA
Supply Current (from REGIN)	USB active		26		mA
	USB suspend mode		330		μA

Pin Number	Signal
1	DCD
2	RI
3	GND
4	D+
5	D-
6	VDD
7	REGIN
8	VBUS
9	RST
11	SUSPEND
12	SUSPEND
23	CTS
24	RTS
25	RXD
26	TXD
27	DSR
28	DTR
10, 13, 14-22	No Connect

CP2102EK Evaluation Kit—A complete HW/SW demonstration of the CP2102 chip and associated software drivers.

The CP2102EK shown below includes the following:

- CP2102TB circuit board with USB connector, CP2102 chip, RS-232 transceiver, and DB-9 connector
- CD ROM with device drivers
- USB cable
- RS-232 cable

Package Information

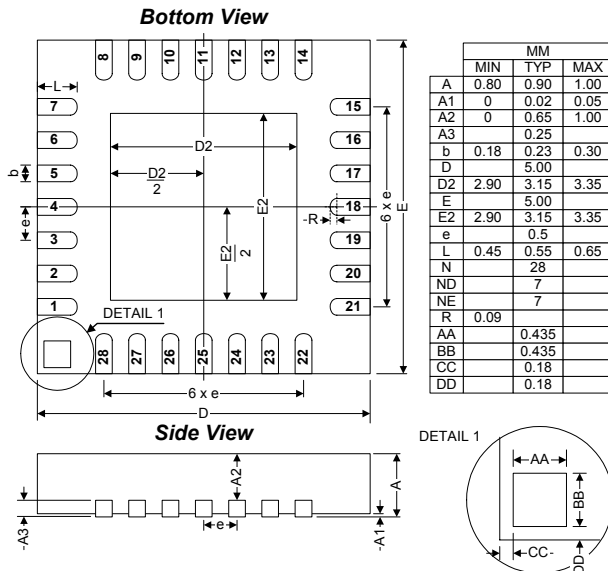

CP2102EK Evaluation Kit

