

## Electronic Line Switch

### Ordering Information

Breakdown Voltage	Switch Resistance	Package Option
		SO-8
375V	15Ω	HT0638LG

### Features

- 15Ω maximum switch resistance
- Current limiting protection
- 4 logic control inputs
- Operates at 2V input
- 2μA maximum quiescent current at 100V

### Applications

- Telephone handsets
- Fax machines
- Answering machines
- Auto-dial alarm systems

### Absolute Maximum Ratings

$V_{TPG}$ , Input line voltage	+375V
$V_{TP}$ , Output line voltage	+18V
HKS continuous input voltage	$V_{TPG}$
LS1, LS2 continuous input voltage	+20V
$\overline{DP}$ continuous input voltage	+5V
Storage temperature	-65°C to +150°C
Soldering temperature*	+300°C

Notes: All voltages are referenced to ground.

\*Distance of 1.6mm from case for 10 seconds.

### General Description

The Supertex HT0638 is an integrated electronic line switches controllable from four logic-level inputs. This device is intended as a replacement for mechanical hook switches and relays in telephones, answering machines, and similar telecommunications equipment. It switches the positive (Tip) side of the telephone line using control inputs that are referenced to the negative (Ring) side of the line. In the off state, it can hold-off 375 volts. In the on state, the series resistance is 15Ω maximum. This device provides adjustable current limiting via an external sense resistor. Three of the control inputs are general purpose and one is an override input that forces the switch to an off state regardless of the state of the other inputs. This override input is useful for 'flash' and pulse dialing purposes. Internal pull-up/down resistors allow the inputs to be driven from single-ended sources, push-pull sources, or left unconnected.

The HT0638 is powered from the phone line and is especially useful in applications where external power is not available. Due to its low quiescent current, this device exceeds the on-hook resistance requirements of EIA-470-A.

### Pin Configuration

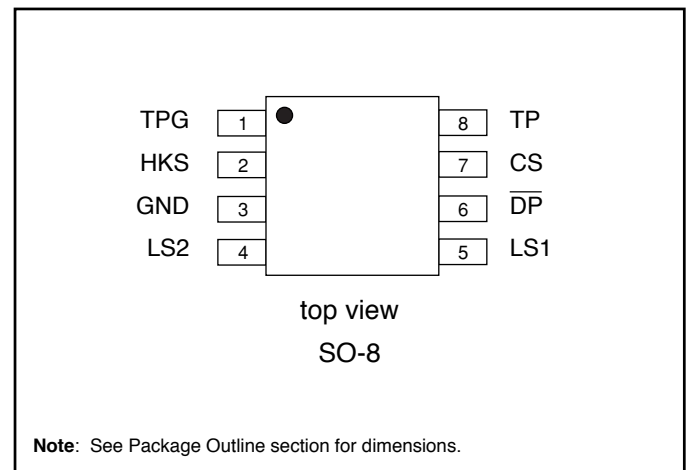

**For additional information, refer to application note AN-H32.**

## Electrical Characteristics

(Over operating supply voltages unless otherwise specified,  $T_A = -40^{\circ}\text{C}$  to  $+85^{\circ}\text{C}$ )

Symbol	Parameter	Min	Typ	Max	Unit	Conditions
$V_{TPG}$	High voltage positive supply			375	V	$I_{TP} = 10\mu\text{A}$ , HKS, LS1, LS2, $\overline{DP}$ = open circuit
$I_{TPQ}$	Input leakage current			2.0	$\mu\text{A}$	$V_{TPG} = 100\text{V}$ , HKS, LS1, LS2, $\overline{DP}$ = open circuit
				10		$V_{TPG} = 375\text{V}$ , HKS, LS1, LS2, $\overline{DP}$ = open circuit
$V_{TP}$	Output voltage	16	18	20	V	$V_{TPG} = 50\text{V}$ , No Load
$R_{SW}$	TPG to TP switch resistance			15	$\Omega$	$V_{TPG}=4.3\text{V}$ , $I_{TPG}=180\text{mA}$ , SW= On
				15		$V_{TPG}=3.0\text{V}$ , $I_{TPG}=20\text{mA}$ , SW= On, $T_A=0^{\circ}\text{C}$ to $50^{\circ}\text{C}$
				30		$V_{TPG}=2.0\text{V}$ , $I_{TPG}=5\text{mA}$ , SW= On, $T_A=0^{\circ}\text{C}$ to $50^{\circ}\text{C}$
$I_{TPG}-I_{TP}$	Bias current			50	$\mu\text{A}$	$V_{TPG} = 5.0\text{V}$ , SW = On
				100		$V_{TPG} = 10\text{V}$ , SW = On
$I_{LIM}$	$I_{TPG}$ current limiting	200		300	mA	$R_{EXT} = 430\Omega$
$I_{HKS}$	HKS input current			200	$\mu\text{A}$	$V_{HKS} = 50\text{V}$
$I_{LS1}$	LS1 input current			136	$\mu\text{A}$	$V_{LS1} = 3.0\text{V}$ , $V_{\overline{DP}} = 0\text{V}$
$I_{LS2}$	LS2 input current			136	$\mu\text{A}$	$V_{LS2} = 3.0\text{V}$ , $V_{\overline{DP}} = 0\text{V}$
$I_{\overline{DP}}$	$\overline{DP}$ output current			500	$\mu\text{A}$	$V_{\overline{DP}} = 0\text{V}$ , $V_{HKS} = 50\text{V}$ , $V_{LS1}=V_{LS2} = 3.0\text{V}$
$V_{IL(HKS)}$	HKS input low	0		0.2	V	
$V_{IH(HKS)}$	HKS input high	2.0		$V_{TPG}$	V	
$V_{IL(LS1)}$ , $V_{IL(LS2)}$	LS1 and LS2 input low	0		0.2	V	
$V_{IH(LS1)}$ , $V_{IH(LS2)}$	LS1 and LS2 input high	1.0		20	V	
$V_{IL(\overline{DP})}$	$\overline{DP}$ input low	0		0.2	V	
$V_{IH(\overline{DP})}$	$\overline{DP}$ input high	1.0		5.0	V	
$T_{ON}$	Turn on time			1.0	ms	$V_{TPG} = 4.5\text{V}$
$T_{OFF}$	Turn off time			1.0	ms	$V_{TPG} = 4.5\text{V}$

## Truth Table

HKS	LS1	LS2	$\overline{DP}$	Switch State
X	X	H	H or Z	ON
X	H	X	H or Z	ON
H	X	X	H or Z	ON
L or Z	L or Z	L or Z	X	OFF
X	X	X	L	OFF

Z = high impedance, open circuit

X = don't care

L = logic level low

H = logic level high

## Typical Performance Curve

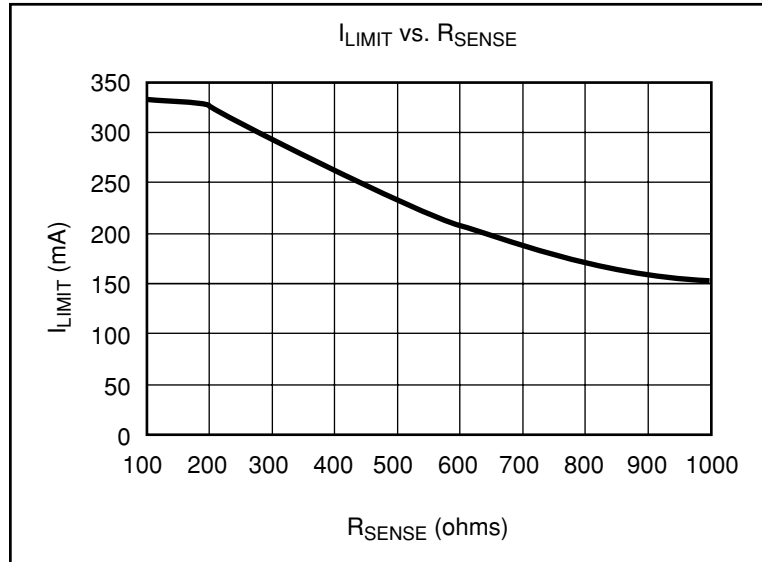

## Block Diagram

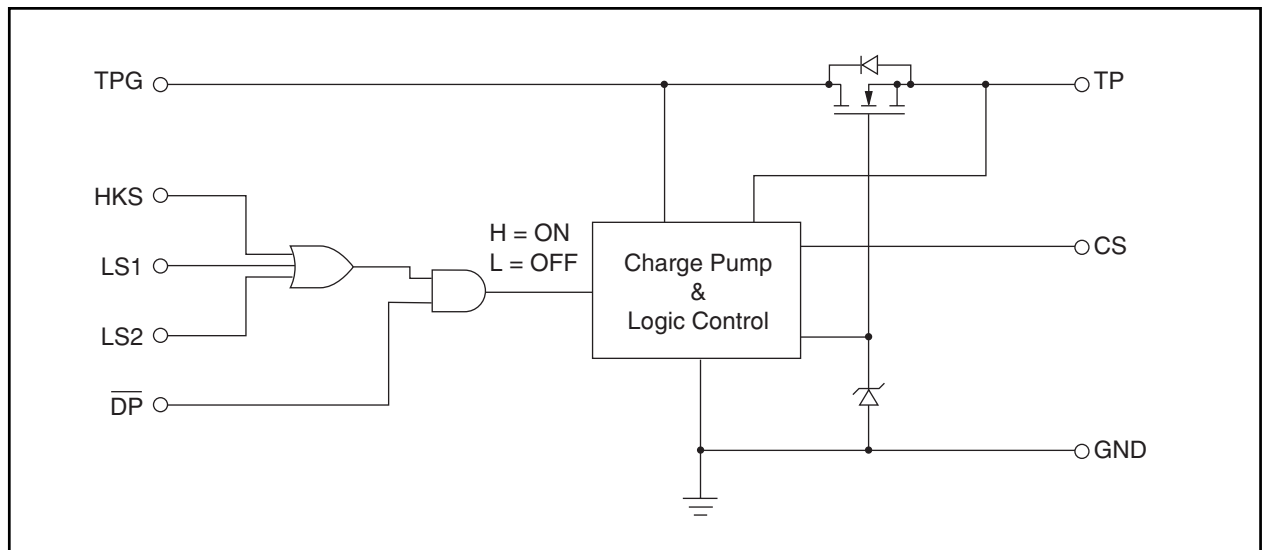

## Pin Description

TPG	Positive input side of a telephone line, typically Tip side.
TP	Positive output side of a telephone line.
HKS	Hookswitch input. Connect HKS to TPG to turn on the electronic switch. Internally pulled low.
LS1	Line switch 1 input. Positive input turns on the electronic switch. Internally pulled low.
LS2	Line switch 2 input. Positive input turns on the electronic switch. Internally pulled low.
DP	Dial pulse input. A low input turns off the electronic switch. Use for pulse dialing. Internally pulled high.
CS	Current sense input. An external resistor connected between CS and TP sets the current limit. Short CS to TP if current sensing is not used.
GND	Device ground. Negative side of a telephone line, typically Ring side.

# Typical Application Circuit

