



Hotswap, Inrush Current Limiter Controllers (Negative Supply Rail)

Features

- HV300, PWRGD=Active HIGH
- HV310, PWRGD=Active LOW
- 10V to -90V Input Voltage Range
- Few External Components
- 0.33mA Typical Standby Supply Current
- Programmable Over/Under Voltage Limits with Hysteresis
- Programmable Current Limit
- Active control during all phases of start-up
- Programmable timing
- 8 Lead SOIC

Applications

- Central Office Switching
- Servers
- POTS Line Cards
- ISDN Line Cards
- xDSL Line Cards
- PBX Systems
- Powered Ethernet for VoIP
- Distributed Power Systems
- Negative Power Supply Control
- Antenna and Fixed Wireless Systems

Ordering Information

V _{EE}		Package Options	
Min	Max	Power Good Signal	8 Pin SOIC
-90V	-10V	Active HIGH	HV300LG
-90V	-10V	Active LOW	HV310LG

General Description

The Supertex HV300 (and HV310), *Hotswap Controller, Negative Supply* control power supply connection during insertion of cards or modules into live backplanes. They may be used in traditional 'negative 48V' powered systems or for higher voltage busses up to negative 90V.

Operation during the initial power up prevents turn-on glitches, and after complete charging of load capacitors (typically found in filters at the input of DC-DC converters) the HV300 (and HV310) issues a power good signal. This signal is typically used to enable the DC-DC converter.

The only difference between the HV300 and the HV310 is the polarity of the PWRGD signal line to accommodate different DC-DC converter models. Once PWRGD signal has been established the device sleeps in a low power state, important for large systems with many individual hotswap cards or modules.

An external power MOSFET is required as the pass element, plus a ramp capacitor, and resistors to establish current limiting and over and under voltage lockouts. There is no need for additional external snubber components.

Features are programmable over voltage and under voltage detection of the input voltage which locks out the load connection if the bus (input) voltage is out of range. An internal voltage regulator creates a stable reference, and maintains accurate gate drive voltage. The unique control loop scheme provides full current control and limiting during start up.

Theory of Operation

Initially the external N-channel MOSFET is held off by the gate signal, preventing an input glitch. After a delay (while internal circuits are activated) the inrush current to the load is limited by the gate control output. The current may ramp up and limit at a maximum value programmed by an external resistor. Initial time delay, to allow for contact bounce, and charging operation is determined by the single external ramp capacitor connected to the RAMP pin. When the load capacitor is fully charged, the controller emerges from current limit mode, an additional time delay occurs before the external N-channel MOSFET pass transistor is switched to full conduction, and the PWRGD output signal is activated. The controller will then transition to a low power standby mode.

The HV300LG PWRGD is active high (open drain), while the HV310LG PWRGD is active low (V_{EE}).

Electrical Characteristics ($V_{IN} = -10V$ to $-90V$, $-40^{\circ}C \leq T_A \leq +85^{\circ}C$ unless otherwise noted)

Symbol	Parameters	Min	Typ	Max	Unit	Conditions
--------	------------	-----	-----	-----	------	------------

Supply (Referenced to V_{DD} pin)

V_{EE}	Supply Voltage	-90		-10	V	
I_{EE}	Supply Current		550	650	μA	$V_{EE} = -48V$, Mode = Limiting
I_{EE}	Standby Mode Supply Current		330	400	μA	$V_{EE} = -48V$, Mode = Standby

OV and UV Control (Referenced to V_{EE} pin)

V_{UVH}	UV High Threshold		1.26		V	Low to High Transition
V_{UVL}	UV Low Threshold		1.16		V	High to Low Transition
V_{UVHY}	UV Hysteresis		100		mV	
I_{UV}	UV Input Current			1.0	nA	$V_{UV} = V_{EE} + 1.9V$
V_{OVH}	OV High Threshold		1.26		V	Low to High Transition
V_{OVL}	OV Low Threshold		1.16		V	High to Low Transition
V_{OVHY}	OV Hysteresis		100		mV	
I_{OV}	OV Input Current			1.0	nA	$V_{OV} = V_{EE} + 0.5V$

Current Limit (Referenced to V_{EE} pin)

V_{SENSE}	Current Limit Threshold Voltage	40	50	60	mV	$V_{UV} = V_{EE} + 1.9V$, $V_{OV} = V_{EE} + 0.5V$
-------------	---------------------------------	----	----	----	----	--

Gate Drive Output (Referenced to V_{EE} pin)

V_{GATE}	Maximum Gate Drive Voltage	9.0	10	11	V	$V_{UV} = V_{EE} + 1.9V$, $V_{OV} = V_{EE} + 0.5V$
I_{GATEUP}	Gate Drive Pull-Up Current	500			μA	$V_{UV} = V_{EE} + 1.9V$, $V_{OV} = V_{EE} + 0.5V$,
$I_{GATEDOWN}$	Gate Drive Pull-Down Current	40			mA	$V_{UV} = V_{EE}$, $V_{OV} = V_{EE} + 0.5V$

Timing Control – Test Conditions: $C = 100\mu F$, $C_{RAMP} = 10nF$, $V_{UV} = V_{EE} + 1.9V$, $V_{OV} = V_{EE} + 0.5V$, External MOSFET is IRF530*

I_{RAMP}	Ramp Pin Output Current		10		μA	$V_{SENSE} = 0V$
t_{POR}	Time from UV to Gate Turn On	2.0			ms	(Note 1)
t_{RISE}	Time from Gate Turn On to V_{SENSE} Limit	400			μs	
t_{LIMIT}	Duration of Current Limit Mode			5.0	ms	
t_{PWRGD}	Time from Current Limit to PWRGD		5.0		ms	
V_{RAMP}	Voltage on Ramp Pin in Current Limit Mode		3.6		V	(Note 2)

Power Good Output (Referenced to V_{EE} pin)

V_{PWRGD}	Power Good Pin Breakdown Voltage	90			V	
V_{PWRGD}	Power Good Pin Output Low Voltage		0.5	0.8	V	$I_{PWRGD} = 1mA$

Dynamic Characteristics

$t_{GATEHLOV}$	OV Delay			500	ns	
$t_{GATEHLUV}$	UV Delay			500	ns	

Note 1: This timing depends on the threshold voltage of the external N-Channel MOSFET. The higher its threshold is, the longer this timing.

Note 2: This voltage depends on the characteristics of the external N-Channel MOSFET. $V_{GS(th)} = 3V$ for an IRF530.

*IRF530 is a registered trademark of International Rectifier.

Timing Diagrams

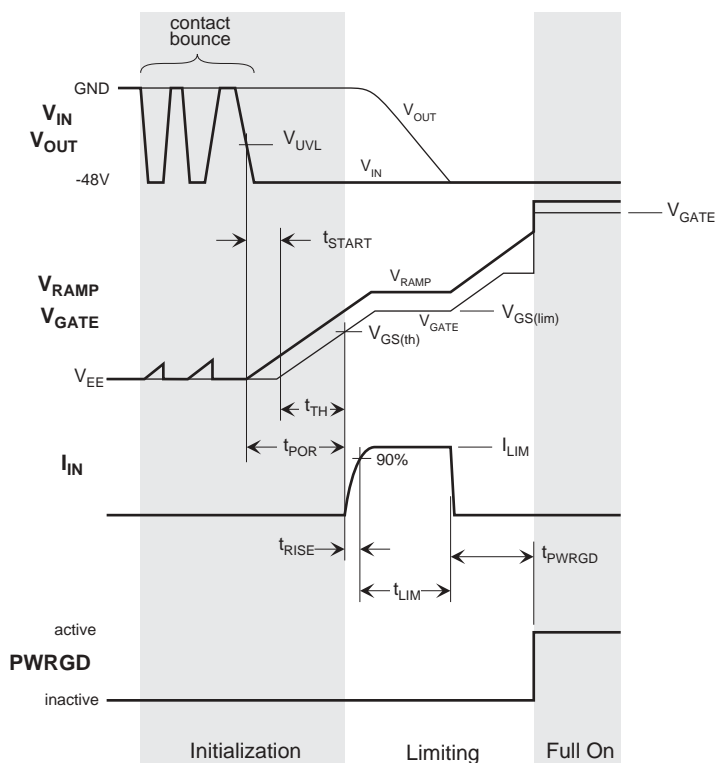

$$I_{LIM} = \frac{V_{SENSE}}{R_{SENSE}}$$

$$t_{START} = 1.2V \frac{C_{RAMP}}{I_{RAMP}}$$

$$t_{TH} = V_{GS(th)} \frac{C_{RAMP}}{I_{RAMP}}$$

$$t_{POR} = t_{START} + t_{TH}$$

$$t_{RISE} \approx \frac{C_{RAMP}}{g_{fs} \left(\frac{I_{RAMP}}{0.9I_{LIM}} - \frac{R_{SENSE}}{R_{FB}} \right)}$$

$$t_{LIM} \approx V_{IN} \frac{C_{LOAD}}{I_{LIM}} - \frac{1}{2} t_{RISE}$$

$$t_{PWRGD} = (V_{INT} - V_{GS(lim)} - 1.2V) \frac{C_{RAMP}}{I_{RAMP}}$$

V_{INT} is the internally regulated supply voltage and can range from 9V to 11V.

$V_{GS(th)}$ is the gate threshold voltage of the external pass transistor and may be obtained from its datasheet.

$V_{GS(lim)}$ is the pass transistor gate-source voltage required to obtain the limit current. It is dependent on the pass transistor's characteristics and may be obtained from the transfer characteristics curves on the transistor datasheet.

g_{fs} is the transconductance of the pass transistor and may be obtained from its datasheet.

R_{FB} is the internal feedback resistor and is 5kΩ nominal.

Absolute Maximum Ratings

V_{EE} reference to V_{DD} pin	+0.3V to -100V
V_{PWRGD} referenced to V_{EE} Voltage	-0.3V to +100V
Operating Ambient Temperature Range	-40°C to +85°C
Operating Junction Temperature Range	-40°C to +125°C
Storage Temperature Range	-65°C to +150°C
UV & OV ref to V_{EE}	-0.3V to +12V

Functional Block Diagram

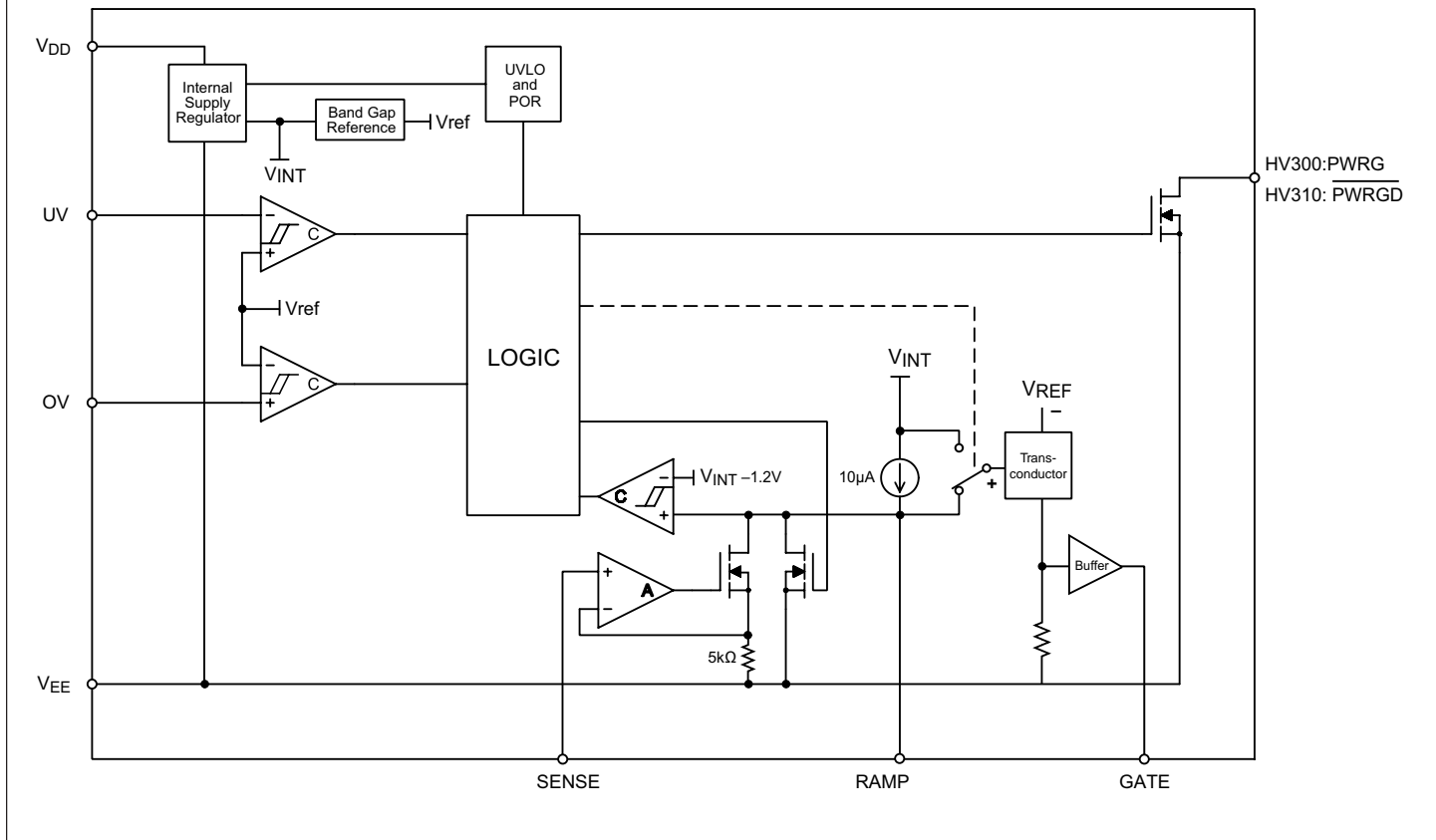

Pinout

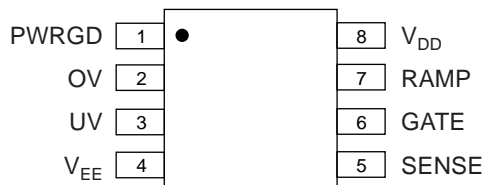

PWRGD Logic

Model	Condition	PWRGD	
HV300	NOT READY	0	V_{EE}
	READY	1	HI Z
HV310	NOT READY	1	HI Z
	READY	0	V_{EE}

Pin Description

PWRGD – The Power Good Output Pin is held inactive on initial power application and will go active when the external MOSFET is fully turned on. This pin may be used as an enable control when connected directly to a PWM power module.

OV – This Over Voltage sense pin, when raised above its high threshold will immediately cause the GATE pin to be pulled low. The GATE pin will remain low until the voltage on this pin falls below the low threshold limit, initiating a new start-up cycle.

UV – This Under Voltage sense pin, when below its low threshold limit will ensure that the GATE pin is low. The GATE pin will remain low until the voltage on this pin rises above the high threshold, initializing a new start-up cycle.

V_{EE} – This pin is the negative voltage power supply input to the circuit.

V_{DD} – This pin is the positive voltage power supply input to the circuit.

RAMP – This pin provides a current output so that a timing ramp voltage is generated when a capacitor is connected. The initial portion of the ramp provides a time delay, which in conjunction with the Under Voltage detection circuit eliminates circuit card insertion contact bounce. The RAMP pin also controls the delay between the current limit mode disengaging and the PWRGD signal activating; as well as the current rise profile after the initial turn on delay.

GATE – This is the Gate Driver Output for the external N-Channel MOSFET.

SENSE – The current sense resistor connected from this pin to V_{EE} pin programs the current limit. Constant current output mode is established when the voltage drop across this resistor reaches 50mV.

Functional Description

Insertion Into Hot Backplanes

Telecom, Data Network and some Computer applications require the ability to insert and remove circuit cards from systems without powering down the entire system. All circuit cards have some filter capacitance on the power rails, which is especially true in circuit cards or network terminal equipment utilizing distributed power systems. The insertion can result in high inrush currents that can cause damage to connector and circuit cards and may result in unacceptable disturbances on the system backplane power rails.

The HV300/HV310 was designed to allow the insertion of these circuit cards or connection of terminal equipment by eliminating these inrush currents and powering up these circuits in a controlled manner after full connector insertion has been achieved. The HV300/HV310 is intended to provide this function on a negative supply rail in the range of -10 to -90 Volts.

Waveforms

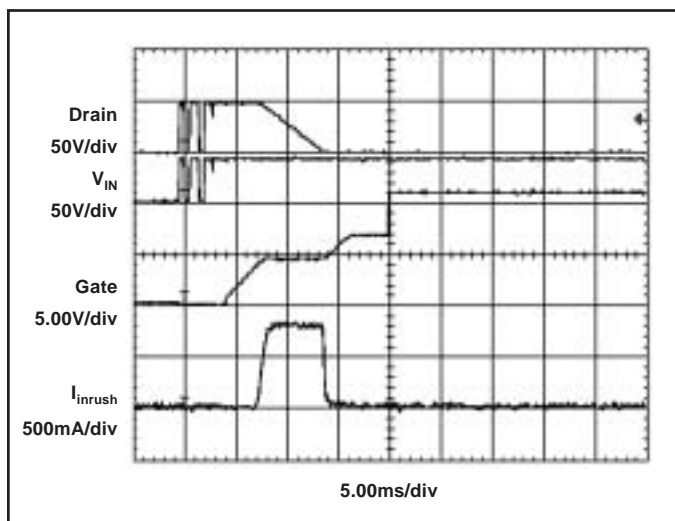

Operation

On initial power application an internal regulator seeks to provide 10 Volts for the internal IC circuitry. Until the proper internal voltage is achieved all circuits are held reset, the open drain PWRGD signal is inactive to inhibit the start of any load circuitry and the gate to source voltage of the external N-channel MOSFET is held low. Once the internal under voltage lock out (UVLO) has been satisfied, the circuit checks the input supply voltage under voltage (UV) and over voltage (OV) sense circuits to ensure that the input voltage is within acceptable programmed limits. These limits are determined by the selected values of resistors R1, R2 and R3, which form a voltage divider.

Assuming the above conditions are satisfied and while continuing to hold the PWRGD output inactive and the external MOSFET GATE voltage low, the current source feeding the RAMP pin is turned on. The external capacitor connected to it begins to charge, thus starting an initial time delay determined by the value of the capacitor. If an interruption of the input power occurs during this time (i.e. caused by contact bounce) or the OV or UV limits are exceeded, an immediate reset occurs and the external capacitor connected to the RAMP pin is discharged.

When the voltage on the RAMP pin reaches an internally set voltage limit, the gate drive circuitry begins to turn on the external MOSFET; allowing the current to softly rise over a period of a few hundred micro-seconds to the current limit set point. While the circuit is limiting current, the voltage on the RAMP pin will be fixed.

Depending on the value of the load capacitance and the programmed current limit, charging may continue for some time. The magnitude of the current limit is programmed by comparing a voltage developed by a sense resistor connected between the V_{EE} and SENSE pins to 50mV (Typical). Once the load capacitor has been charged, the current will drop which will cause the ramp voltage to continue rising; providing yet another programmed delay.

When the ramp voltage is within 1.2V of the internally regulated voltage, the controller will force the GATE full on and will activate the PWRGD pin and the circuit will transition to a low power standby mode. The PWRGD pin is often used as an enable for downstream DC/DC converter loads.

At any time during the start up cycle or thereafter, crossing the UV and OV limits (including hysteresis) will cause an immediate reset of all internal circuitry. Thereafter the start up process will begin again.

Typical Application Circuit

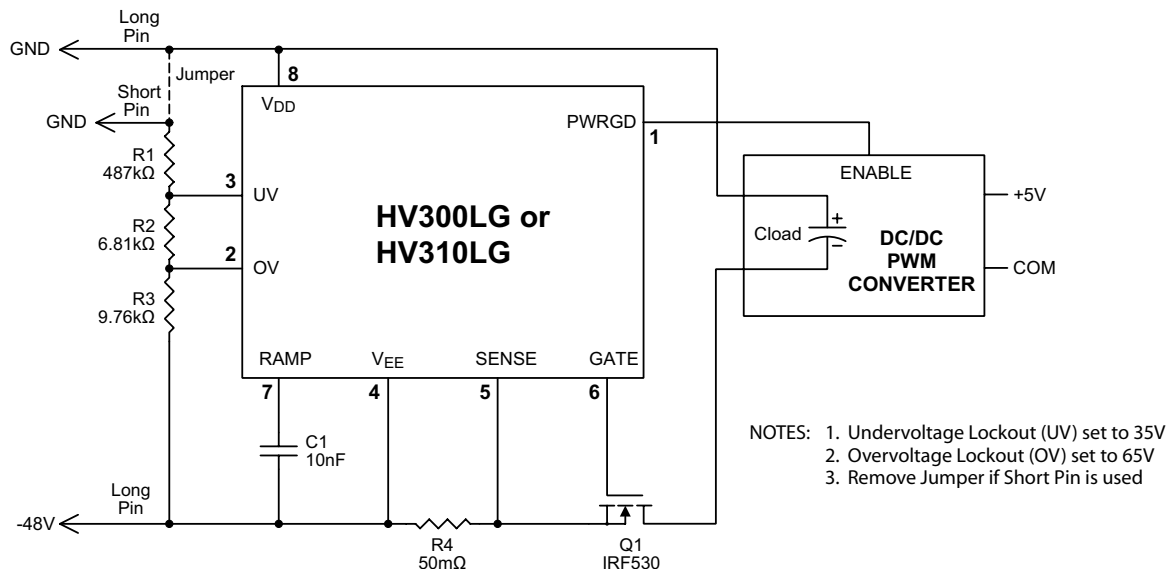

Application Information

Under Voltage and Over Voltage Detection

The UV and OV pins are connected to comparators with nominal 1.21V thresholds and 100mV of hysteresis ($1.21V \pm 50mV$). They are used to detect under voltage and over voltage conditions at the input to the circuit. Whenever the OV pin rises above its threshold or the UV pin falls below its threshold the GATE voltage is immediately pulled low, the PWRGD signal is deactivated and the external capacitor connected to the RAMP pin is discharged.

The under voltage and over voltage trip points can be programmed by means of the three resistor divider formed by R1, R2 and R3. Since the input currents on the UV and OV pins are negligible the resistor values may be calculated as follows:

$$UV_{off} = V_{UVH} = 1.16 = |V_{EEUV}| * (R2+R3) / (R1+R2+R3)$$

$$OV_{off} = V_{OVL} = 1.26 = |V_{EEOV}| * R3 / (R1+R2+R3)$$

Where $|V_{EEUV}|$ and $|V_{EEOV}|$ are Under & Over Voltage Set points.

If we select a divider current of $100\mu A$ at a nominal operating input voltage of 50 Volts then

$$(R1+R2+R3) = 50V / 100\mu A = 500k\Omega$$

From the second equation for an Over voltage set point of 65 Volts the value of R3 may be calculated.

$$OV_{off} = 1.26 = 65 * R3 / 500k\Omega$$

$$R3 = (1.26 * 500K) / 65 = 9.69 k\Omega$$

The closest 1% value is 9.76k Ω .

From the first equation for an Under Voltage set point of 35 Volts the value R2 can be calculated.

$$UV_{off} = 1.16 = 35 * (R2 + R3) / 500K$$

$$R2 = (1.16 * 500K) / 35 - 9.76k\Omega = 6.81k\Omega.$$

The closest 1% value is 6.81k Ω .

$$\text{Then } R1 = 500K - (R2 + R3) = 483k\Omega$$

The closest 1% value is 487k Ω .

Undervoltage/Overvoltage Operation

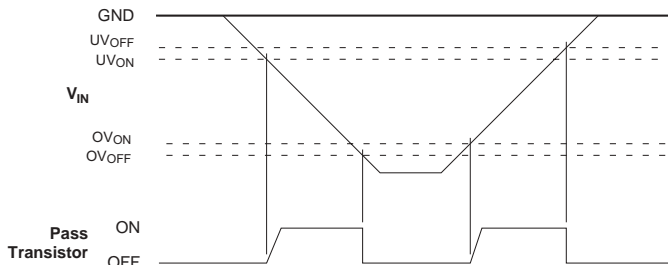

Current Limit

The current limit magnitude above which the current will not be allowed to rise during startup is programmed using a sense resistor connected from the SENSE pin to V_{EE} pin. For example to program a current limit of 1A, one would choose a resistor as follows:

$$R_{sense} = 50mV / I_{sense}$$

$$R_{sense} = 50mV / 1A$$

$$R_{sense} = 50m\Omega$$